

SQUARE VALVE DESIGN

DESCRIPTION

A balanced ventilation system requires intake and exhaust valves. The valves are set to the air flows prescribed and required. The air flows are laid down by law and calculated in advance by your installer. It is extremely important not to make any changes to the valve settings once these have been set as this could disrupt the correct operation of the ventilation system. The valves must not be interchanged.

The design is specifically created to regulate the air intake and extraction, and it simply fits onto the regulating valve. The user can simply turn the design cover by a quarter turn to dismantle it for cleaning purposes. This ensures that the regulating valve remains safely in place on the ceiling without affecting any of the settings.

The design valve is made from aluminium that is KTL-coated with an S600 structural paint and it can also be repainted. It is always supplied with the smiley 2.0 regulating valve included.



DIMENSIONAL DRAWING

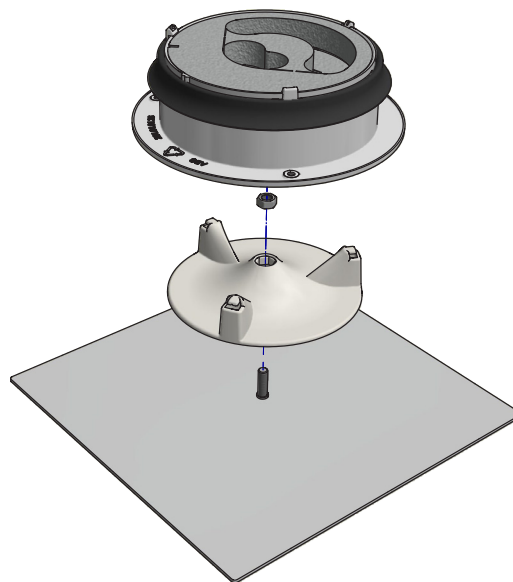
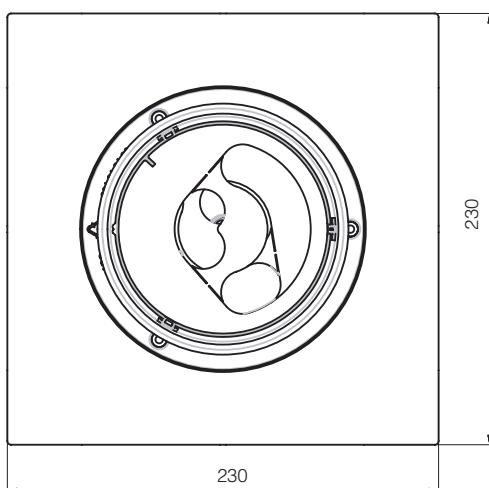
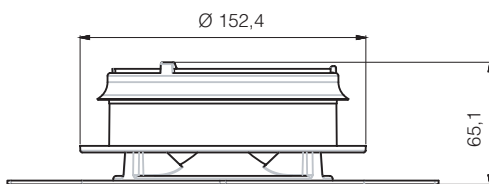

Dimensions in mm